

# TRIMJOIST

EXACT FIT. ON TIME. EVERY TIME.

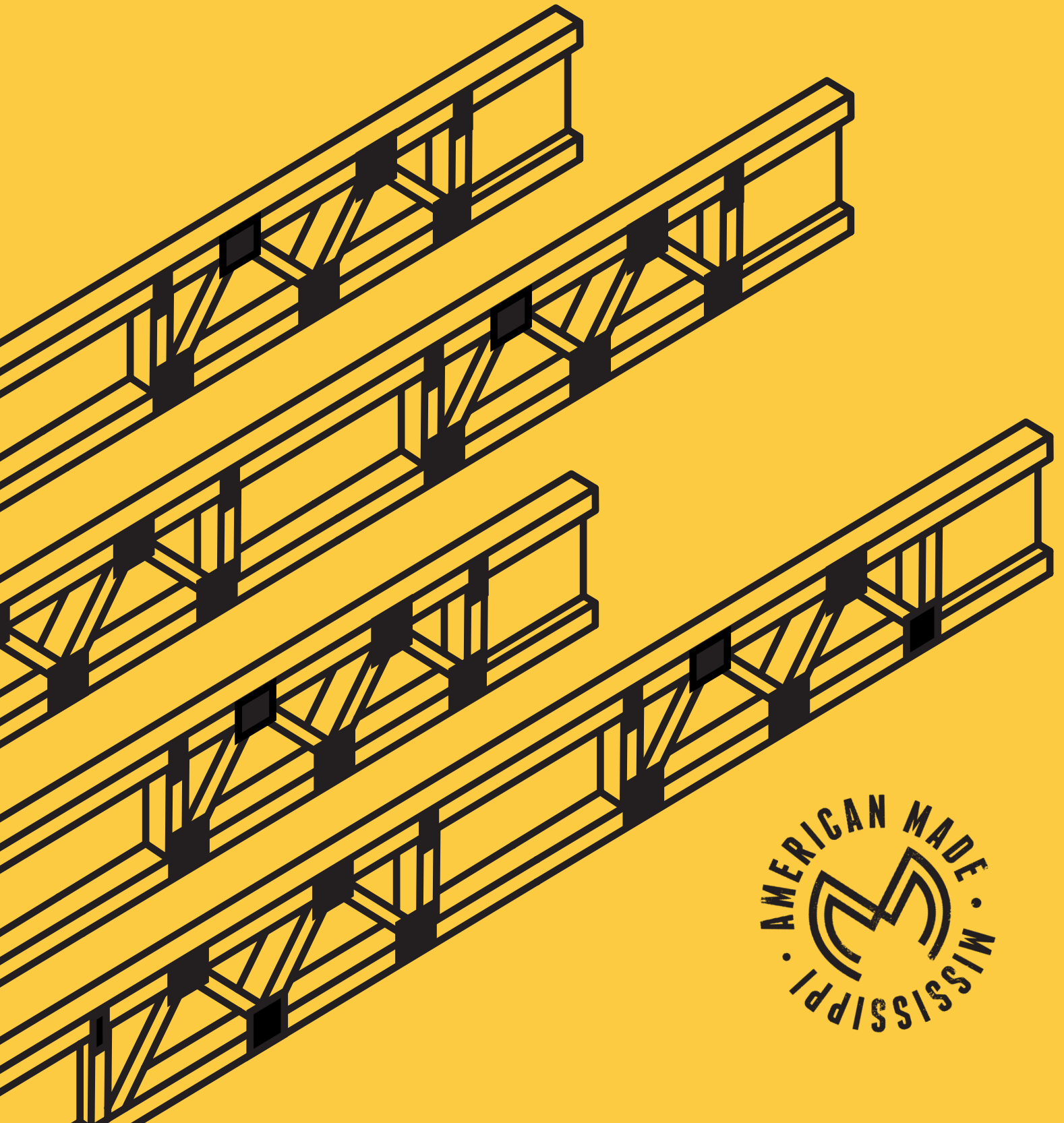

## TECHNICAL GUIDE



# KEY POINTS



**SILENCE.** The TrimJoist® provides a full 3-1/2" wide surface for the proper nailing and gluing of subfloor materials. By providing such a wide surface, the TrimJoist® allows the builder to use sub-floor framing tolerances that will prevent squeaks. The wide surface also allows for the application of sufficient glue to make the TrimJoist® and the subfloor truly act as a unified system.

**QUALITY.** The TrimJoist® addresses product consistency and product quality from three key perspectives:

**DESIGN.** The TrimJoist® was initially designed using the most capable structural engineers and computer software systems available from both inside and outside the forest products industry. This includes the PPSA system from Purdue University as well as Rasna finite element software from Parametric Technology.

**MATERIAL CONTROL.** All raw material components are structurally rated by various independent agencies such as the Truss Plate Institute (TPI), Southern Pine Inspection Bureau (SPIB), American Plywood Association (APA), American Society for Testing and Materials (ASTM), and of course ANSI. In fact, all TrimJoist® floor trusses now conform to the new ANSI/TPI 1-2014 standard. In addition, all lumber components of the TrimJoist® are subject to a strict "cull" process where questionable pieces are discarded before entering into the production process.

**SERVICE.** Put simply, the TrimJoist® is the superior product for floor joist applications. To aid architects, building designers, and contractors we offer toll-free access to a TrimJoist® representative. By simply calling (800) 844-8281 you can gain immediate assistance with your question or framing issue.

**PRODUCTION TESTING.** In addition to the rigorous testing performed on prototype units during the development phase of the TrimJoist®. All production runs are subject to periodic, random tests. These tests are conducted to the standards of the Truss Plate Institute (TPI) Test Truss Specification. No other production floor truss is subjected to such ongoing scrutiny and improvement.

**ENVIRONMENT.** The TrimJoist® design allows for the utilization of lumber from plantation-grown trees, thus sparing the "old-growth" forests that are necessary to produce all traditional wide-board joists. In addition, our engineered strength allows for longer spans and greater on-center spacing. This not only reduces construction costs, but can reduce the board footage of wood fiber required by up to 12% over traditional joists. By design, approximately 40% of the TrimJoist® material content is from recycled sources. In addition, our manufacturing process recovers over 97% of its generated waste.

**INNOVATION.** The TrimJoist® is produced in stock lengths that range from 4' to 30', in standard 2-foot increments. Because each joist has 12-inches of trim at each end, a continuous range of spans is possible. Complex angled walls? No problem for the TrimJoist®.

The open web design of the TrimJoist® allows for the utilization of that valuable floor cavity space. It's now practical for duct work, wiring, and plumbing to be contained within this cavity. This eliminates unsightly and expensive furring. Free access to the floor cavity requires no cutting or notching that can severely impair the structural integrity of other joists products of inferior design.

# TABLE OF CONTENTS <<<



TrimJoist® is an open-web, trimmable floor truss system that offers unparalleled strength, fit and usability for today's demanding and time-conscious contractor.

04 Product Profile
05 Residential Span Charts
06 Heavy Load Span Charts
07 Bonus Room Span Charts
08 Fire Resistance
08 Web Opening Sizes
09 Typical End Framing
10 Good Framing Practices
11-15 Floor Framing Details
15 Framing Connectors
16 Installation Notes
17 Safety & Handling Notes
18 Construction Dead Loads
18 iPad App Information
19 Architectural Specifications

# PRODUCT PROFILES

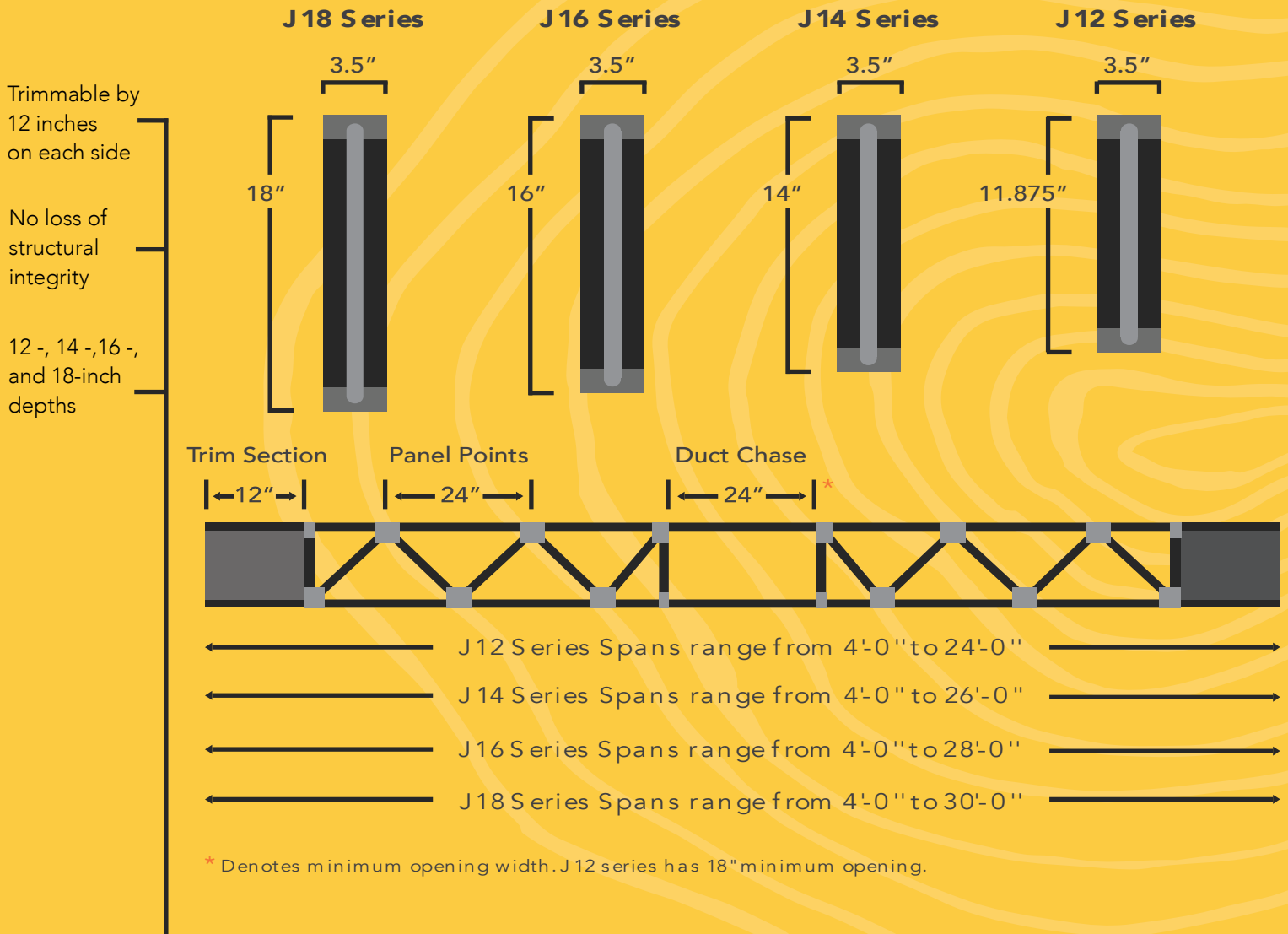

The engineered strength of the TrimJoist<sup>®</sup> system provides for longer spans and wider on-center spacing. Joists come in two-foot incremental lengths, beginning at 4 feet and spanning as far as 30 feet and can be trimmed by up to 24 inches.

# RESIDENTIAL SPAN CHART



OPTIMAL PERFORMANCE						
40 PSF Live Load + 15 PSF Dead Load = 55 PSF Total Load						
Live Load Deflection based on L/480						
Series	Depth	Deflection	12" o.c.	16" o.c.	19.2" o.c	24" o.c.
J12	11 7/8"	L/480	24'-0"	23'-2"	21'-9"	20'-2"
J14	14"	L/480	26'-0"	26'-0"	24'-7"	22'-9"
J16	16"	L/480	28'-0"	28'-0"	27'-1"	25'-1"
J18	18"	L/480	30'-0"	30'-0"	29'-6"	27'-2"

HIGH PERFORMANCE						
40 PSF Live Load + 15 PSF Dead Load = 55 PSF Total Load						
Live Load Deflection based on L/600						
Series	Depth	Deflection	12" o.c.	16" o.c.	19.2" o.c	24" o.c.
J12	11 7/8"	L/600	23'-8"	21'-6"	20'-2"	18'-8"
J14	14"	L/600	26'-0"	24'-3"	22'-8"	21'-0"
J16	16"	L/600	28'-0"	26'-8"	25'-1"	23'-2"
J18	18"	L/600	30'-0"	29'-1"	27'-4"	25'-3"



## GENERAL NOTES:

1. Spans are based on uniformly loaded joists and include allowances for repetitive use members.
2. All TrimJoist® floor joists have a TOP orientation and should not be installed upside-down.
3. Limit total reaction (per end) to that indicated in the Maximum Reaction Table.
4. Stiffness factors (L/xxx) assume a minimum 3/4-inch span-rated subfloor that has been both glued and nailed.
5. Do not apply center supports, cantilevers, concentrated or asymmetrical continuous loads without first consulting a Trimjoist representative.

## ABOUT FLOOR STIFFNESS:

Floor performance is greatly influenced by joist stiffness. Experience has shown that a floor system designed to minimum code acceptance may not meet the expectation of discerning owners. TrimJoist® Corporation strongly recommends that floor spans be limited to those indicated in the optimal performance chart above. Also, using a higher live load deflection limit such as L/600 as shown in the high performance chart above will result in a stiffer floor. The numbers in these charts far exceed minimum code requirements and are based on both gluing and nailing the subfloor. In cases where the subfloor is nailed only, spans remain the same, but the stiffness must be reduced by 20%. For optimal performance use screws in lieu of nails.

# HEAVY LOAD SPAN CHARTS



OPTIMAL PERFORMANCE						
50 PSF Live Load + 15 PSF Dead Load = 65 PSF Total Load						
Live Load Deflection based on L/480						
Series	Depth	Deflection	12" o.c.	16" o.c.	19.2" o.c.	24" o.c.
J12	11 7/8"	L/480	23'-8"	21'-6"	20'-2"	18'-8"
J14	14"	L/480	26'-0"	24'-3"	22'-9"	21'-0"
J16	16"	L/480	28'-0"	26'-8"	25'-1"	23'-2"
J18	18"	L/480	30'-0"	29'-1"	27'-4"	25'-3"

## DESIGN NOTES:

The uniform load span charts shown indicate the maximum design spans (including a 1 3/4" minimum bearing evenly trimmed) for each family of the TrimJoist® floor system. Most residential designs require a minimum of 55 psf loading. Floors used for heavy traffic and/or heavy floor coverings (e.g. tile) should be designed at 65 psf minimum. All loads are broken down into LIVE, TOP-DEAD and BOTTOM-DEAD components. For example, the 55 psf column is really 40 psf live plus 10 psf top-dead plus 5 psf bottom-dead for a total of 55 psf total load. Dead loads are the weight of the construction materials and are always present for the whole life of the structure. Live loads, on the other hand, are transient and are never constant over the life of the structure. These charts are for uniformly loaded, simply supported joists. For special applications requiring concentrated loads, asymmetric continuous loads, cantilevers, or special bearing conditions, please consult a Trimjoist representative or authorized dealer.

MAX REACTION TABLE	
Width	Max
1 3/4"	3000
3 1/2"	3500
5 1/2"	4000

Note: Width is the width of the loaded wall above or the bearing wall width - whichever is less.

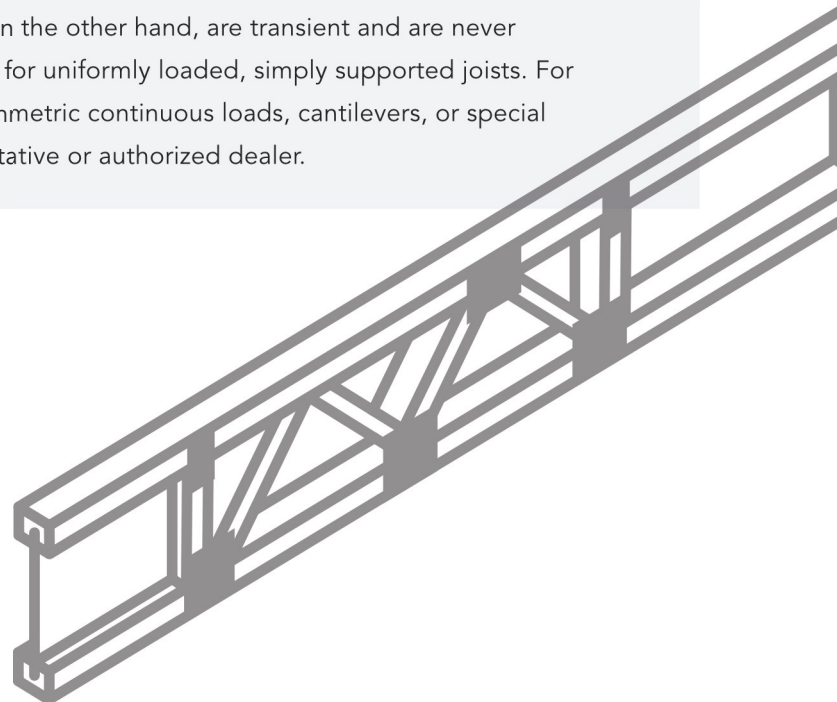

# BONUS ROOM DETAILS

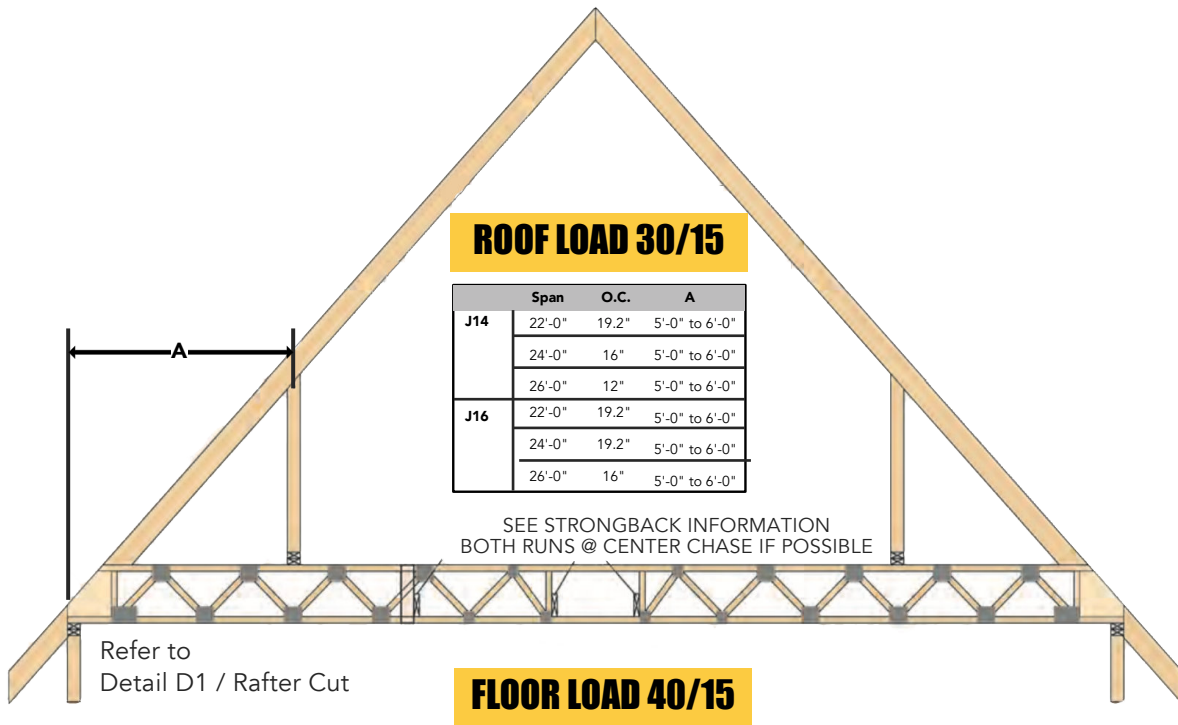

# STRONGBACK INFO

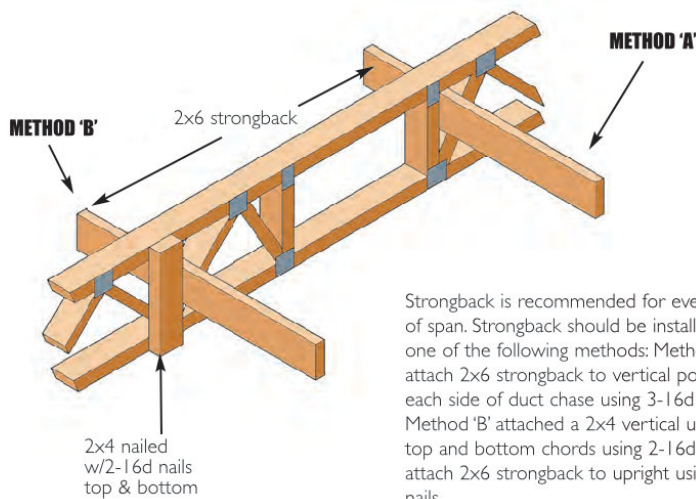

Strongback is recommended for every 10'-0" of span. Strongback should be installed using one of the following methods: Method 'A' attach 2x6 strongback to vertical posts on each side of duct chase using 3-16d nails. Method 'B' attached a 2x4 vertical upright to top and bottom chords using 2-16d nails and attach 2x6 strongback to upright using 3-16d nails.

# FIRE RESISTANCE RATED ASSEMBLIES



FIRE RESISTANCE RATED TRUSS ASSEMBLIES		
Category	Construction Materials	Report Number
1-HOUR RATING	Floor System Spacing 24" O.C. Minimum 12" Depth Furring channel 24" O.C., Alt. Resilient Channel 16" O.C.	UL-L528
	1 Layer 5/8" Type 'C' Gypsum Sheathing Minimum 23/32"	UL-L534
	Floor System Spacing 24" O.C. Minimum 12" Depth 2-Layers 1/2" Type 'X' Gypsum Sheathing Minimum 23/32"	UL-L542
2-HOUR RATING	Floor System Spacing 24" O.C. Minimum 12" Depth Resilient channel 24" O.C. 3-Layers 5/8" Type 'C' Gypsum Sheathing Minimum 23/32"	Calculated Assembly (Report Available)
	Floor System Spacing 24" O.C. Minimum 12" Depth Resilient channel 24" O.C. 4-Layers 5/8" Type 'X' Gypsum Sheathing Minimum 23/32"	UL-L556

## NOTES:

1. The tables shown are only summaries of the fire rated assembly reports. Users must consult the listed agency's documentation for complete information.
2. Some rated assemblies are tested using specific branded products. Substitutions may not be made without approval. An assembly using generic products may be available.
3. Additional information concerning Fire Resistance Rated Truss Assemblies may be found online at [www.woodtruss.com](http://www.woodtruss.com).

# WEB OPENING SIZES

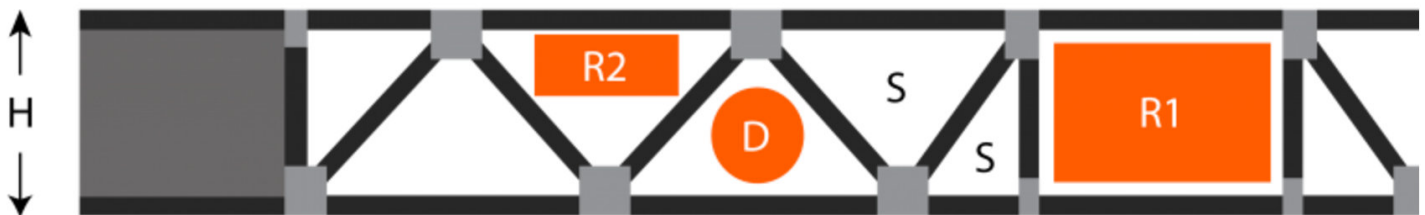

OPENING SIZES				
	J12	J14	J16	J18
H	11 7/8"	14"	16"	18"
D	6"	8"	9"	10"
R1	8x16	10x24	12x24	14x24
R2	4X9	4X10 6X6	4X12 6X8	4X14 6X10 8X8



# TYPICAL END FRAMING

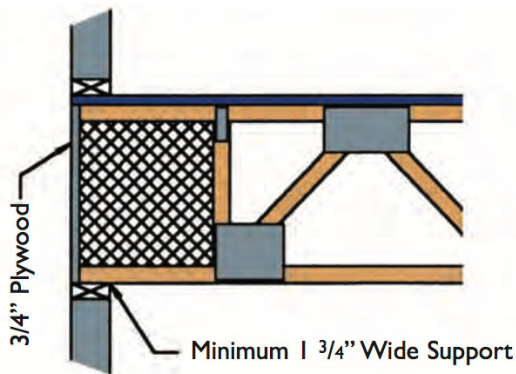

**DETAIL B1 - 3/4" BANDING**

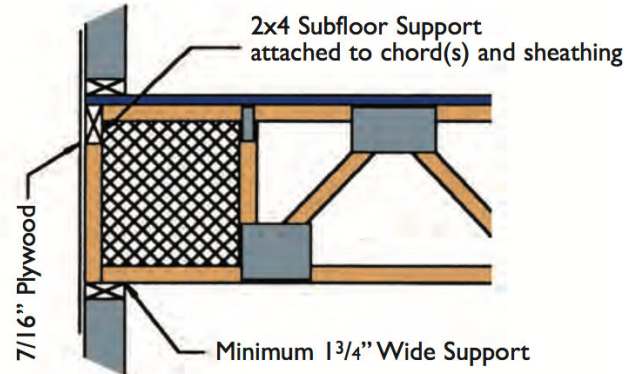

**DETAIL B2 - 2x4 BANDING**

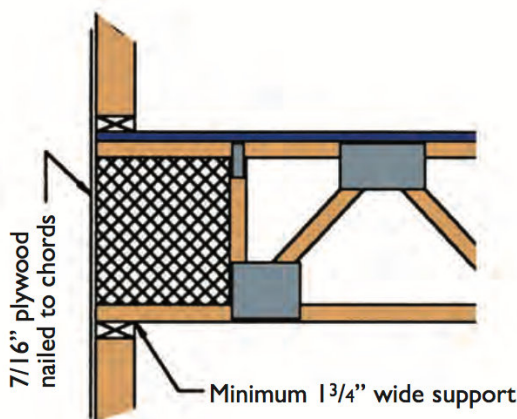

**DETAIL B3 - DIAPHRAM BANDING**

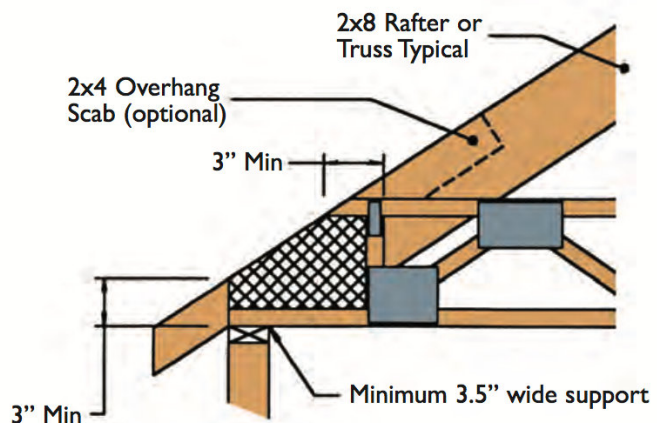

**DETAIL D1 - RAFTER CUT**

## NOTES ON END BANDING:

In most single and two story residential applications, the TrimJoist® does not require any ribbon banding to achieve structural performance. This is due to the thickness of the OSB web material and the close proximity of the vertical web stiffener. However, the building designer may require such banding for other purposes. The end details are those typically encountered. Contact a Trimjoist representative for more information on special framing conditions.

# GOOD FRAMING PRACTICES



## DO'S

- DO** Install TrimJoist® right side up. TOP is stamped on the top of each joist.
- DO** Make sure that each TrimJoist® bears on the bottom chord beneath the TrimEnd section or beneath the first metal plate if the TrimEnd section has been removed.
- DO** Use strongback stiffeners. Although not required for structural performance, strongback adds additional resistance to impact loadings.
- DO** Provide appropriate bear width at each end of the TrimJoist®. The required width can be found in the Maximum Reaction Table on page 4. Use vertical web stiffeners where reactions exceed these values.
- DO** Use TrimJoist® approved hangers for flush-mounted bearing conditions. These may be purchased from your local TrimJoist® dealer.
- DO** Use an appropriately rated sub-floor that has been both glued and nailed/screwed to the top chord of the TrimJoist®.
- DO** Consult your TrimJoist® dealer or representative about special loading or bearing conditions not addressed in this Guide.

## DO NOT'S

- DO NOT** cut any part of the TrimJoist® except for the TrimEnd sections which are specifically designed to be field cut.
- DO NOT** remove, cut or alter any metal plate connector on the TrimJoist® without first consulting a factory engineer.
- DO NOT** install the TrimJoist® upside down without first consulting a TrimJoist® factory engineer.
- DO NOT** use a TrimJoist® as a header or beam except as may be instructed by a TrimJoist® engineer.
- DO NOT** allow the TrimJoist® to be supported by the top chord. All support must be from under the bottom flange.
- DO NOT** depend on "toenailing" to provide adequate support capacity for flush-mounted framing. Consult your local TrimJoist® dealer or a TrimJoist® factory engineer for proper hanger selection.
- DO NOT** apply special support or load conditions without first consulting a TrimJoist® representative.



# FLOOR FRAMING DETAILS

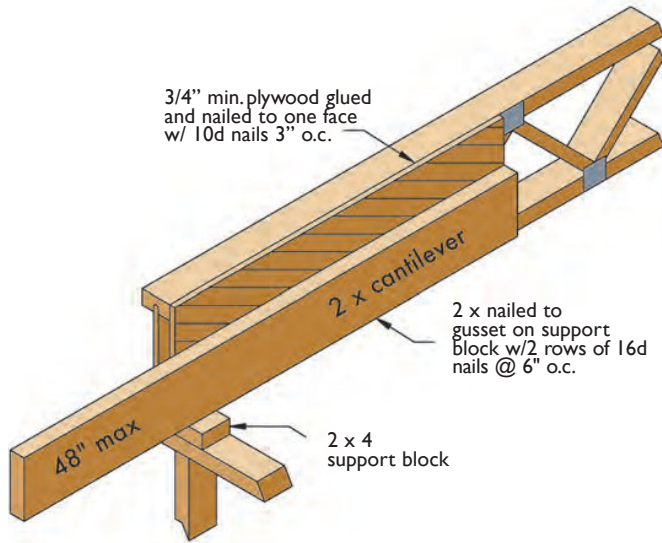

**D2**

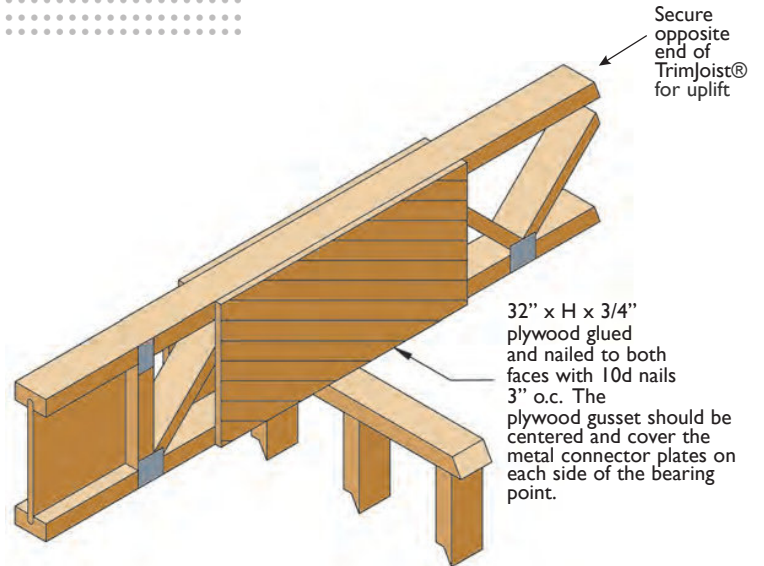

**D3**

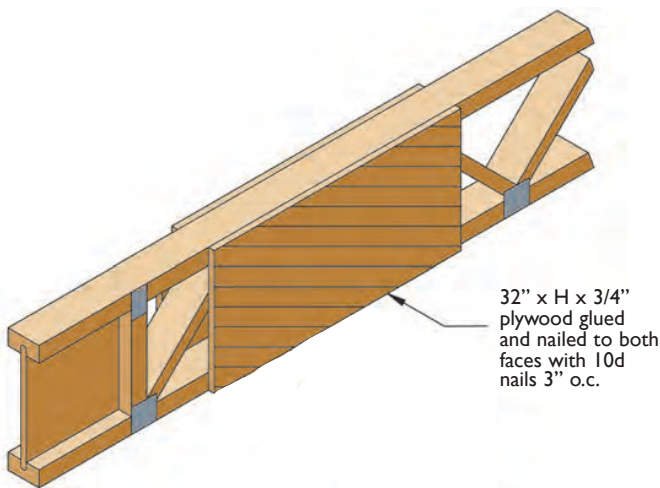

**D4**

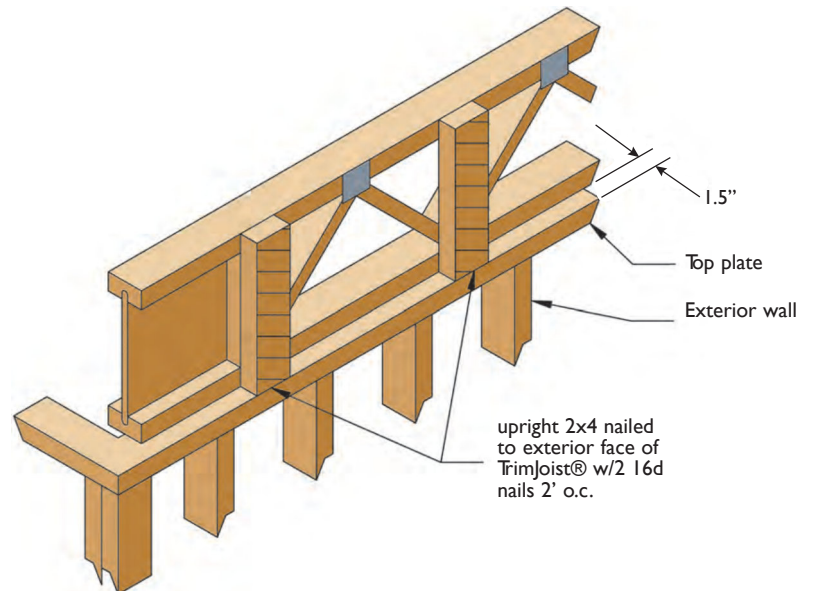

**D5**

# FLOOR FRAMING DETAILS

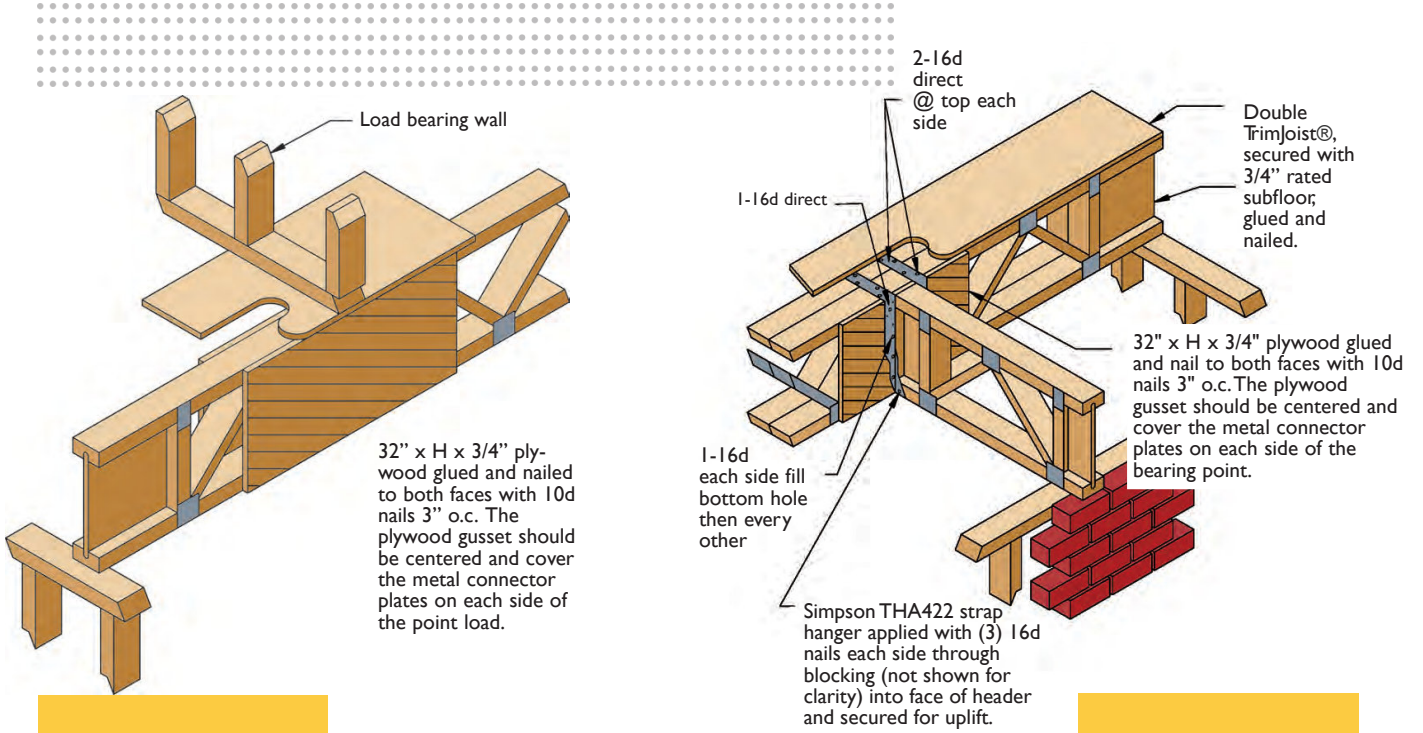

**D6**

**D7**

**D8**

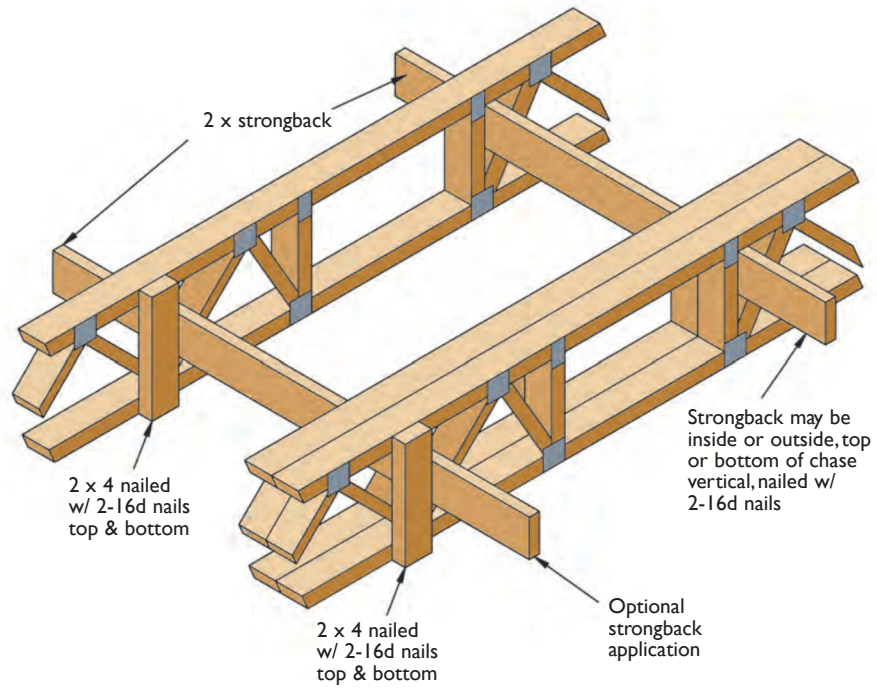

# FLOOR FRAMING DETAILS

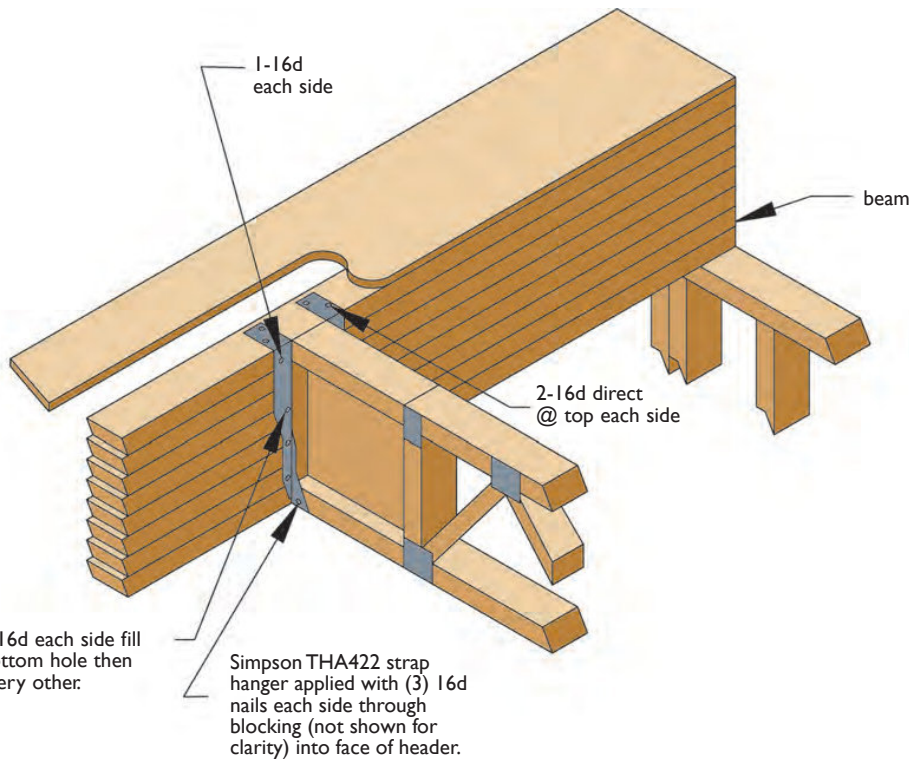
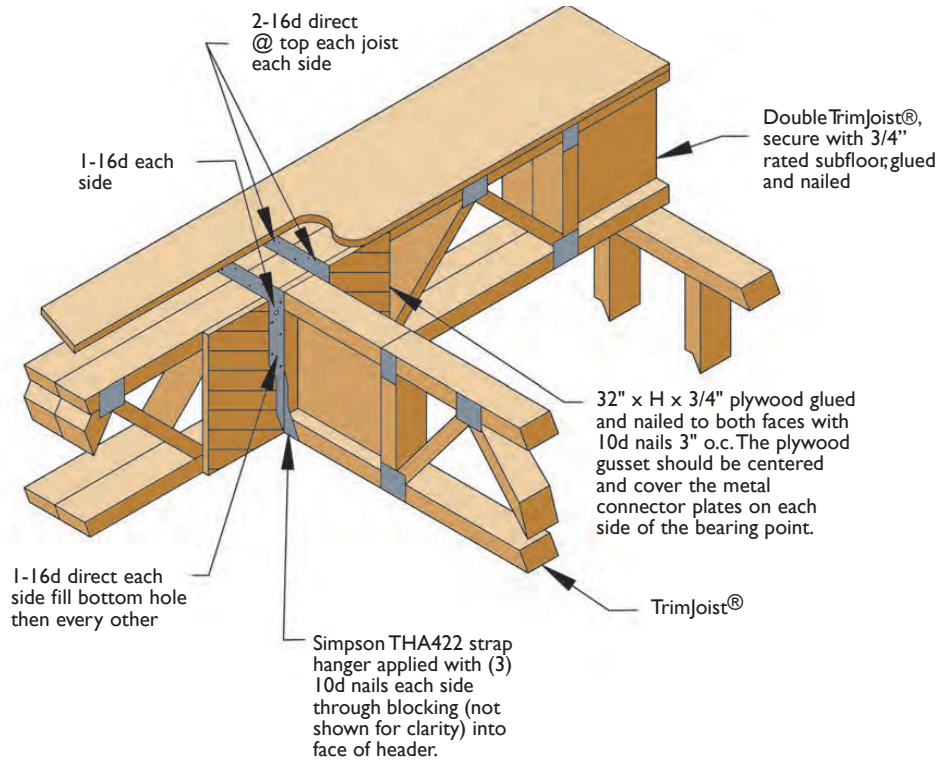

# FLOOR FRAMING DETAILS

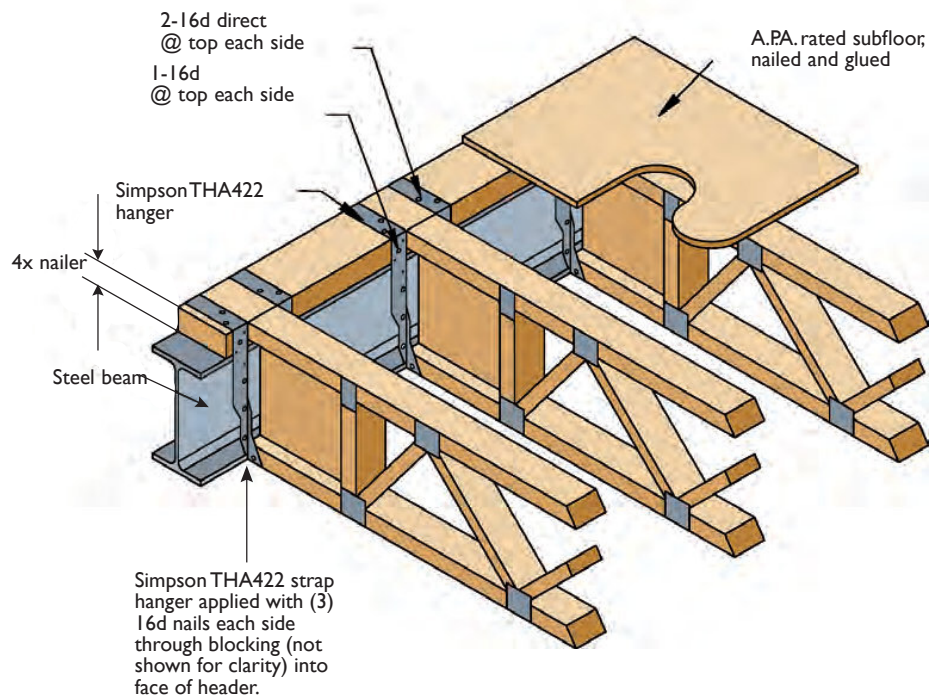
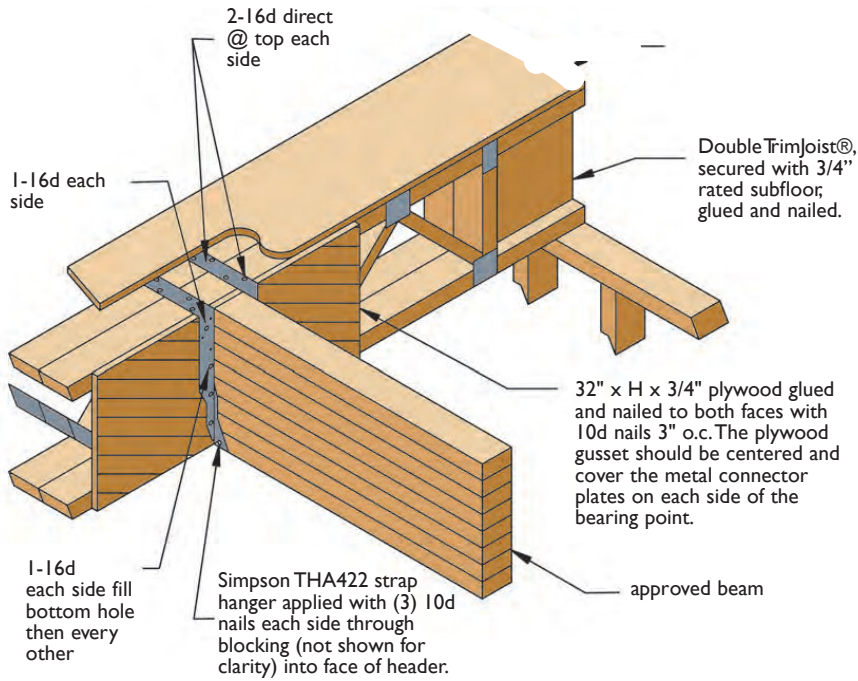

# FLOOR FRAMING DETAILS

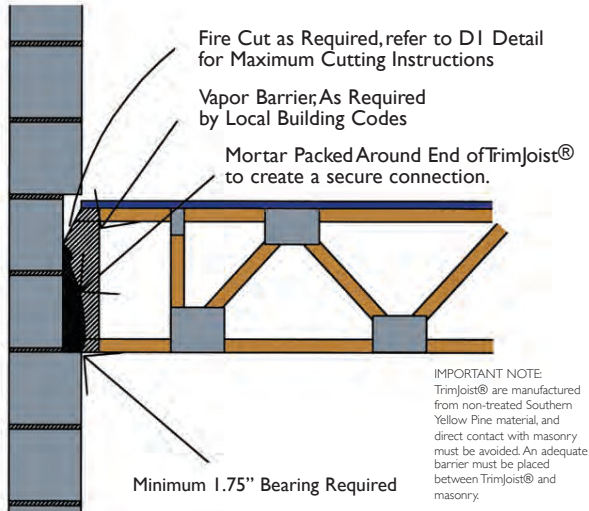

**MASONRY FIRE CUT DETAIL**

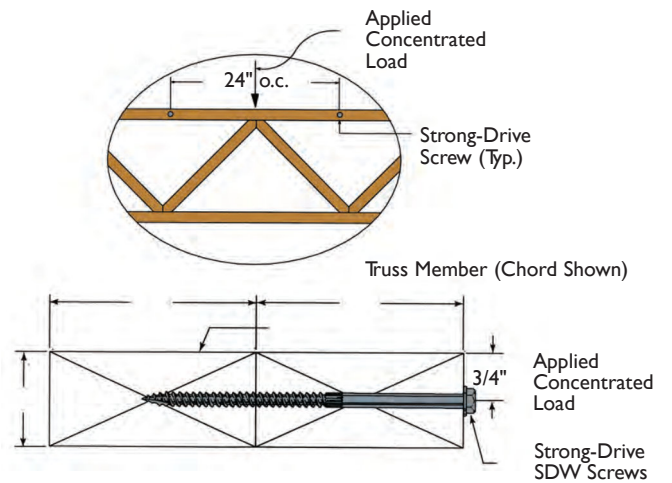

**MULTI-PLY CONNECTION DETAIL**

# FRAMING CONNECTORS

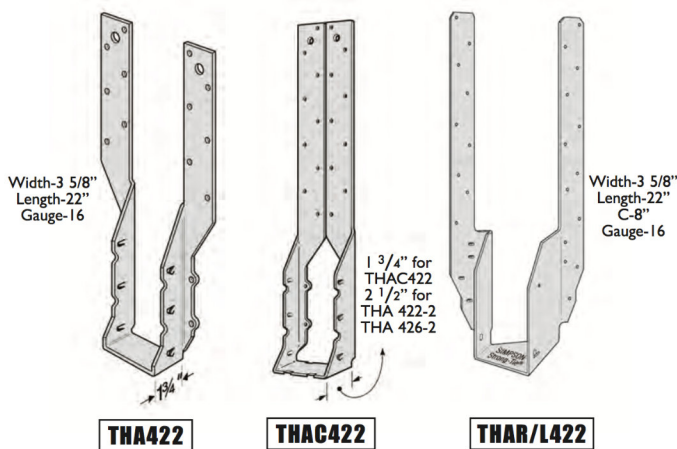

**NOTES ON FRAMING CONNECTORS:**

For minimum/maximum nailing installation methods and blocking, refer to Simpson Strongtie Catalog at [www.strongtie.com](http://www.strongtie.com).

Courtesy of Simpson Strong-Tie Co., Inc.

# INSTALLATION NOTES



- Except for cutting to length, top and bottom chords of TrimJoist®s shall not be cut, drilled or notched.
- Concentrated loads shall only be applied to the upper surface of the top chord, not suspended from the bottom chord. Contact TrimJoist® engineers for exceptions.
- Any fastening, resistance to uplift or member not specifically detailed is subject to local approval.
- End bearing length must be at least 1-3/4".
- TrimJoist® must not remain in direct contact with concrete or masonry construction and shall be used in dry use conditions only.
- TrimJoist®s must be restrained against rotation at the end of joists by use of rim joists, 2x end banding, or cross bridging.
- Install vertical web stiffeners to transfer loads from above to the wall or foundation below if they exceed the values found in the Maximum Reaction Table.
- Plywood or OSB subfloor nailed to the top chord of a TrimJoist® is adequate to provide lateral support.
- Any fastening, resistance to uplift or member not specifically detailed is subject to local approval.
- TrimJoist®s are not stable until completely installed, and will not support any load until fully braced and sheathed.
- Do not allow workers to walk on TrimJoist® until joists are fully installed and braced, or serious injuries can result.
- Never install a damaged TrimJoist®.

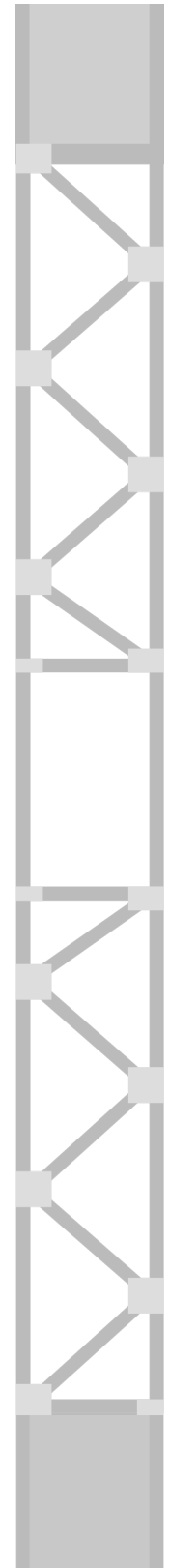



# SAFETY WARNING



TrimJoist®s will not support workers or other loads until properly installed and braced. To minimize risk of injury, each TrimJoist® shall be properly fastened as it is erected. Continuous closure and/or 2x end banding must be installed and attached prior to installing floor or roof sheathing. Lateral restraint, such as an existing deck or braced end wall must be established at the ends of the bay. Alternately, a temporary or permanent deck (sheathing) may be nailed to the first 4 feet of joists at the end of the bay. Rows of temporary bracing at right angles to joists must be fastened with a minimum of two 8d nails (10d box nails if net thickness of bracing exceeds 1") to the upper surface of each parallel joist and the established lateral restraint. Bracing should be 1x4 minimum and at least 8' long with on-center spacing not to exceed 10'. Ends of adjoining bracing should lap over at least two joists. Stack building materials over main beams or walls only.

Improper storage or installation, failure to follow applicable building codes, failure to follow proper load tables, or failure to use plywood gussets when required can result in serious accidents. Installation notes and good framing practices must be followed carefully.

# STORAGE HANDLING



- Bundles should be stored upright on a smooth, level, well-drained supportive surface.
- Bundles should not be in contact with the ground.
- Bundles should remain wrapped, strapped and protected from the weather until time of installation.
- Place 2x spacers (at a maximum of 10' apart) between bundles and the ground, and bundles stored on top of one another.
- Be careful when handling TrimJoist®s with a forklift or crane.
- When handling Trimjoist®s, they should remain vertical.
- Avoid excessive bowing during all phases of handling and installation (i.e. measuring, sawing, or placement)
- Damage may result if the joist is twisted or a load is applied to it while it's lying flat.

# CONSTRUCTION DEAD LOADS



CEILING	
Acoustical Fiber Tile	1.0 psf
1/2" Gypsum Board	2.0 psf
5/8" Gypsum Board	2.5 psf
Plaster (1" thick)	8.0 psf
Metal Suspension System	0.5 psf
Wood Suspension System	2.0 psf

SHEATHING AND DECKING	
1/2" Plywood	1.5 psf
5/8" Plywood	1.8 psf
3/4" Plywood	2.3 psf
Tectum (1" thick)	2.0 psf
Poured Gypsum (1" thick)	6.5 psf
Vermiculite (1" thick)	2.7 psf

MISCELLANEOUS	
Sprinkling System (Dry)	1.5 psf
Ductwork (24g)	3.0 psf
Rigid Fiberglass (1" thick)	1.5 psf
Roll Insulation (6" thick)	1.8 psf

FLOORS	
Hardwood (1" thick)	3.8 psf
Concrete	
Regular (1" thick)	12.0 psf
Lightweight (1" thick)	8.0 psf
Carpet & Pad	2.0 psf
3/4" Ceramic or Quarry Tile	2.0 psf
3/4" Gyp-Crete	6.5 psf

WALL WEIGHTS - typical 8' wall	
Interior (16" O.C. studs)	64 plf
Composition Exterior (Add)	35 plf
Brick Exterior (Add)	320 plf

COMPOSITION ROOFING	
235 lb Shingles & Paper	2.5 psf
2-15 lb and 1-90 lb	1.7 psf
3-15 lb and 1-90 lb	2.2 psf
3-Ply and Gravel	5.6 psf
4-Ply and Gravel	6.0 psf
Clay Tile	10 psf
Spanish Tile	19 psf

## IPAD APP



Trimjoist's iPad app, **iJoist**, is an analysis and information utility for architects, engineers, and building designers using TrimJoist® open-web joist components. iJoist can be used during the preliminary design stages of a project as an aid for determining the suitability and performance of TrimJoist® components at various loadings, spans, spacings, and depths. TrimJoist® products are typically used as floor joists or roof/ceiling rafters in both residential and light commercial projects.

# ARCHITECTURAL SPECIFICATIONS



## PART 1-GENERAL

### 1.0-Description

- A. Work in this section includes: Prefabricated, field-fit, open web floor trusses for use as floor joists.
- B. Related work specified elsewhere: Rough carpentry

### 1.1-Submittals:

- A. Product Data:  
Submit manufacturer's descriptive literature indicating material composition, thicknesses, dimensions and loading details.
- B. Shop Drawings:  
Submit drawing indicating installation details. Include locations and details of any blocking and/or bridging as required.

### 1.2-Quality Assurance:

- A. Certification:  
Certify the manufacturer uses materials that are tested and appropriately rated by proper industry governing agencies.

### 1.3-Delivery, Storage and Handling:

- A. Delivery:  
Deliver materials to the job site in the manufacturer's original packaging, containers and bundles with manufacturer's brand name and identification intact and legible.
- B. Storage and Handling:  
Store and handle materials to protect them against contact with damp and wet surfaces, exposure to weather, breakage and damage. Individual joists shall be handled in the upright position.

### 1.4-Limitations:

- A. Loads:  
Concentrated loads shall not be applied to the bottom chord or web members.
- B. Cutting:  
Except for cutting to length, top and bottom chords of floor truss joist shall not be cut, drilled or notched.
- C. All floor trusses shall be used in covered, dry conditions only.

## PART 2-PRODUCTS

### 2.0-Prefabricated Open Web Floor Trusses:

- A. Acceptable products:  
Trimjoist Corporation  
J12, J14, J16, or J18 as required.
- B. Characteristics:
  1. Chords should be 3.5" wide, minimum #1 grade Southern Pine.
  2. Diagonal webbing should be precision cut Southern Pine attached to the chords with steel plates certified by TPI.
  3. Floor truss height to be as needed for loading, span and o.c. spacing.
  4. Floor truss to be engineered to allow for exact length adjustment in the field so as to assure that all bearing requirements are met.

### 2.1-Accessories:

- A. Nails: 10d and 16d common nails.
- B. Blocking and Strongback:  
Filler blocks to be placed at bearing locations only where reactions are excessive. Strongback to be placed as directed by local building code. (Strongback not required for structural performance).
- C. Joist Hangers:  
All specified hangers are Simpson 3 1/2" wide seat hangers unless otherwise indicated. Call Trimjoist Corporation for these and other hangers that may be needed.

## PART 3-EXECUTION

### 3.0-General:

- A. Provide 2x4 field-fit parallel chord trusses for floor joists and ceiling rafters where indicated on drawings. Provide metal hangers and other accessories as may be needed.
- B. Install parallel chord trusses in accordance with manufacturer's recommendations. Install to prevent domino-ing during construction.



## WARRANTY INFORMATION <<<

Trimjoist Corporation warrants its products to be free from defects in material and workmanship as generally accepted in the industry. Said products are further warranted as to adequacy of design, provided products are used in strict accordance with Trimjoist Corporation's then currently published design limits and are installed in a workmanlike manner. Said warranties do not apply in the event products are altered in any way other than intended by design. Trimjoist Corporation's obligations under this warranty shall be limited to the replacement or repair of those products demonstrated to be defective. Such remedy shall constitute Customer's sole and exclusive remedy and customer, through the use of this product, agrees that no other remedy (including, but not limited to claims for INCIDENTAL, CONSEQUENTIAL or SPECIAL DAMAGES, or ANY CAUSE, LOSS, ACTION, CLAIM or DAMAGE, INCLUDING LOSS OF TIME whatsoever, or INJURY TO PERSONS OR PROPERTY or ANY OTHER CONSEQUENTIAL DAMAGE or INCIDENTAL or ECONOMIC LOSS) shall be available to customer whether said claims be asserted on the basis of warranty, negligence, strict liability, or otherwise. THIS WARRANTY IS EXPRESSLY IN LIEU OF ALL OTHER WARRANTIES, EXPRESSED OR IMPLIED, INCLUDING ANY WARRANTIES OF MERCHANTABILITY AND FITNESS FOR ANY PARTICULAR PURPOSE. ALL OF SUCH OTHER WARRANTIES BEING HEREBY EXPRESSLY EXCLUDED.

U.S. Patent 5,761,872 • U.S. Patent 6,139,667



Trimjoist Corporation  
5146 Highway 182 East  
Columbus, Mississippi 39702

800.844.8281  
info@trimjoist.com  
www.trimjoist.com